

Technical Specifications: Vol au vent

Lilyclaire Major + Clara Laurent

Length of number: 6 minutes

The length, music, style, as well as the required amount space are adaptable

Dimensions of performance space :

Width: 10m (33ft)

Length: 6m (20ft)

Height (unobstructed/under the lights): Minimum 7m (23ft)

**The big landing mat can be replaced by a "fly mat"

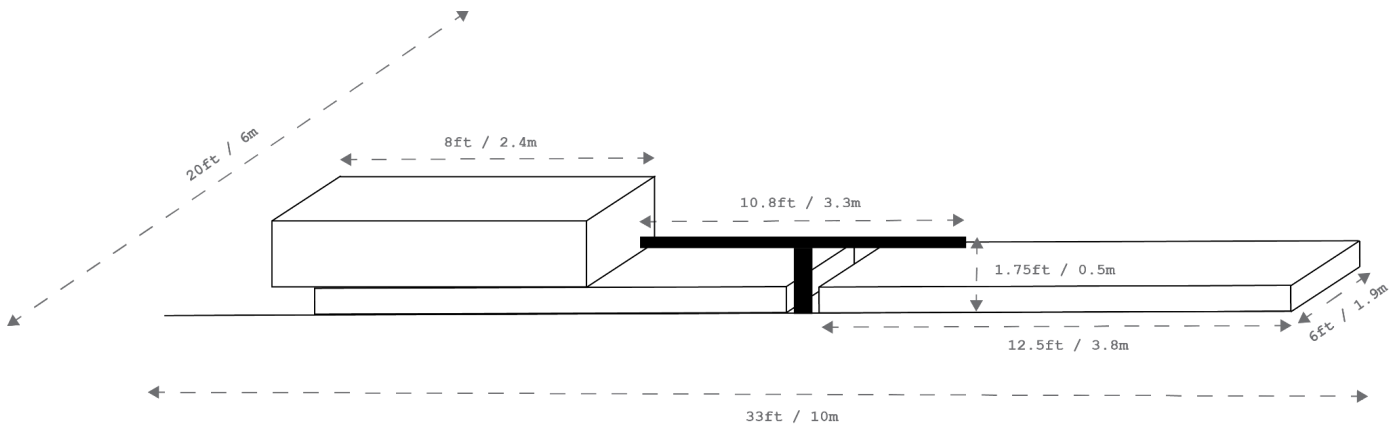

Set up requirements:

A minimum of 30 minutes need to be reserved for set up in the performance space

The installation must be verified by a certified acrobatic rigger (the cost of which must be assumed by the producer)

All installations, structures, and equipment must adhere to the technical requirements described on this sheet

The floor/stage must be level, smooth, solid, clean and capable of resisting forces of up to **800 lbs**

In order to facilitate the installation, a 4th person (ideally a stage technician) is needed to lift the 90 kg teeterboard onto the stage

The artists of Vol au vent reserve the right to verify the installation and equipment themselves and to communicate directly with the riggers and technicians

Transport

The producer must allow the unloading and loading of the truck as close to the performance space as possible

The teeterboard is moved with a dolly as it is extremely heavy

The producer must allow the truck to be parked near the performance space during the performance (if required, a parking permit must be provided by the producer)

In the case that the number is presented over several days and the producer has offered the possibility of storing the equipment between performances, the storage space must be monitored

An average performance day

Access to a green room and warm-up space is needed 2 hours before the performance

The team will arrive 2.5 hours before the performance

Unloading of the equipment with help from the technicians/show team (30 min)

Set up of the equipment on stage (30 min)
Sound and lighting check (45 min)
Warm-up and rehearsal for the artists (30 min)
Performance
Take down and load the equipment (30 min)

Lighting

For safety reasons, **NO** strobe lights, moving lights, or side lights (on stage right and left) while the artists are jumping
A qualified lighting technician must be present during the performance

Unless otherwise specified, **the artists** will provide:

- Music
- Makeup
- Costumes
- The apparatus (the teeterboard)

The producer will provide:

- A flat and level performance space
- Audio equipment for playing music during the performance
- The required mats
- A clean, adequate lighting, and heated green room with a mirror, floor space to warm-up, and access to a bathroom as well as drinkable water

For more information, don't hesitate to contact us at vol.ouvert.cirque@gmail.com or **+1-858-302-8146**